

3D Structures on Fiber Tip

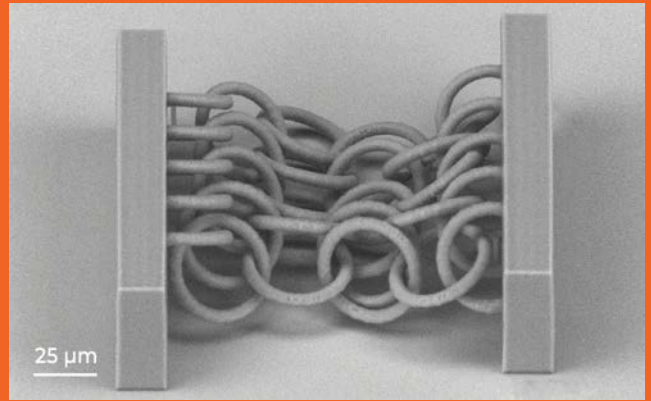

3D Chain-Mail Structure

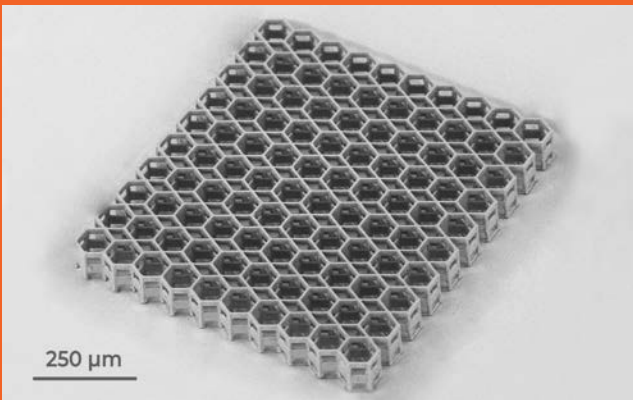

3D Scaffold

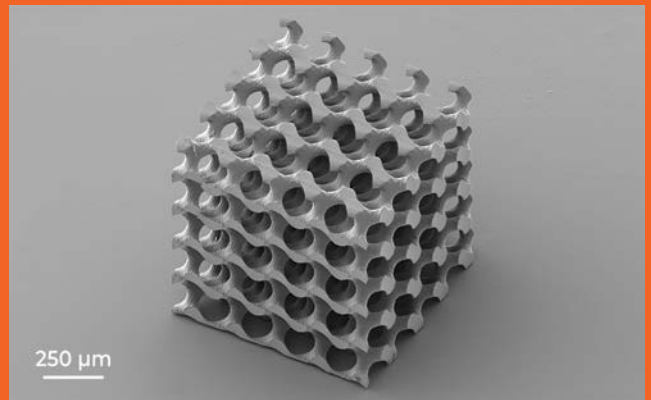

3D Gyroid Structure

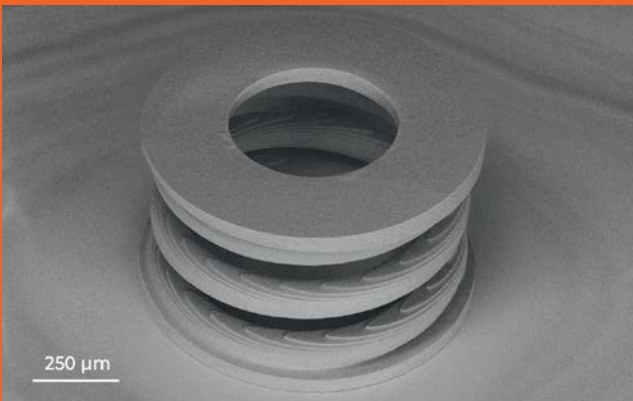

3D Meso-Spring

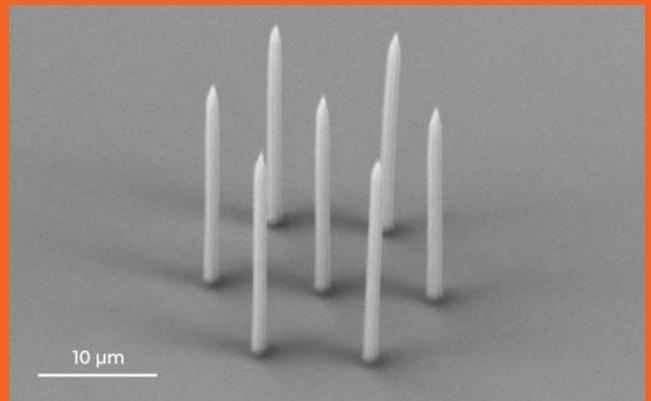

Microneedles



3D Scaffold

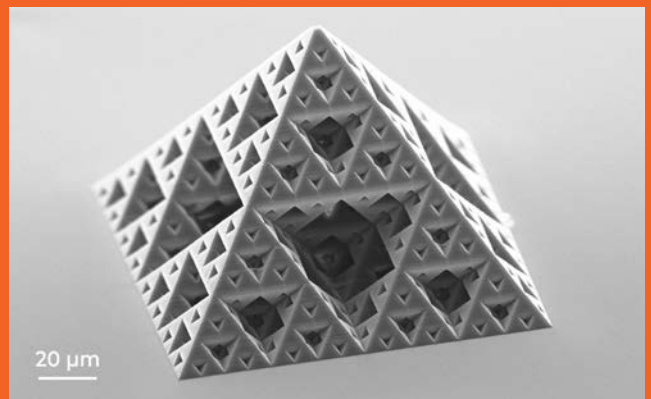

3D Gyroid Structure

MULTIPHOTON POLYMERIZATION



APPLICATIONS

- Micro-optics
- Micro-mechanics
- Scaffolds
- Sensors
- Interconnects

FEATURES

- Nanometer resolution additive manufacturing technique
- True 3D structures in micrometer scale
- Various polymers available
- Stitching error-free manufacturing

Multiphoton-polymerization (MPP) is a technology that enables the production of arbitrary shape polymeric structures within submicrometric resolution. First, a photoresist sample is prepared by drop-casting polymer material mixed with a photoinitiator on the glass slide and then pre-baking. Afterward, the 3D microstructure is fabricated using a direct laser writing technique. Consequently, the polymer hardens in places of drop where it is affected by laser radiation due to a process called photopolymerization. Finally, the microstructure is immersed in an organic solvent to develop an unpolymerized photoresist.

MPP is often used in the manufacturing of microelectronic devices, as it allows for the creation of very small and detailed structures with high levels of precision. Additionally, because the light is highly focused, it can be used to create complex 3D shapes.

SPECIFICATIONS

Technology	Additive manufacturing
Materials	SZ2080, SU-8, Ormocers, Glassomer, hybrid organic-inorganic photopolymers, elastomers, proteins
Minimum XY feature size	150 nm
Minimum surface roughness Ra	≤ 20 nm
Maximum fabrication speed	30 mm/s

TECHNICAL SPECIFICATIONS

Technology	Multiphoton Polymerization	Selective Laser Etching	Hybrid
------------	-----------------------------------	--------------------------------	---------------

LASER SOURCE

Femtosecond laser	Wavelength	780 nm	1030 ± 10 nm 515 ± 10 nm		1030 ± 10 nm	1030 ± 10 nm and 515 ± 10 nm
	Repetition rate	100 MHz	11 MHz ... 76 MHz	Single-shot – 1 MHz	Single-shot – 1 MHz	Single-shot – 1 MHz
	Pulse duration	< 100 fs	50 fs 120 fs 170 fs	290 fs – 20 ps (tunable)	250 fs (450 fs) – 10 ps (tunable)	190 fs – 10 ps (tunable)
	Max. average power	250 mW	2 W	5 W	10 W	from 5 W to 20 W*
	Long-term power stability	< 0.5% RMS over 24 h	< 0.5% RMS over 100 h			

POSITIONING

Linear stages with synchronized Galvano scanners	XYZ POSITIONING STAGES MOUNTED ON GRANITE BASE WITH BRIDGE					
	Travel (XYZ)	160 mm × 160 mm × 60 mm *				
	Accuracy (XYZ)	± 300 nm				
	Resolution (XYZ)	1 nm				
	Maximum speed (XY)	200 mm/s				
	GALVANO SCANNERS					
	Accuracy	50 µrad				
	Repeatability	0.4 µrad RMS				

OTHER PARAMETERS

Monitoring on time	The fabrication process is monitored by an integrated machine vision system		
Stitching	Stitchless fabrication using Infinite Field of View (IFoV)		
Focusing optics	Objectives – from 0.4 to 1.4 NA *	Objectives – from 0.25 to 0.45 NA *	Objectives – from 0.25 to 1.4 NA *
Autofocus system	Automatic glass/polymer or glass/air interface optical detection		
Self-Align-System (SAS)	Automatic laser beam path alignment system		
Substrate	Universal vacuum sample holder with computer-controlled, position synchronized illumination for transparent samples		

Technology	Multiphoton Polymerization	Selective Laser Etching	Hybrid
Beam delivery & control	Motorized attenuator, polarization rotator, beam expander. Integrated power meter enables real-time power monitoring		
Software	Convenient control of all necessary process parameters and machine settings. The software handles standard formats of 3D designs created by popular CAD programs, like STL		
Laser safety	Ergonomic housing to ensure laser safety class 1 and environment stability conditions for laser microfabrication process		

* Customizable.

PHYSICAL DIMENSIONS

Dimensions when all doors are closed (W × L × H)	1790 mm × 920 mm × 2270 mm
Dimensions when doors are opened (W × L × H)	2680 mm × 1900 mm × 2300 mm
Weight	~ 700 kg

ENVIRONMENTAL & UTILITY REQUIREMENTS

Operating temperature	20 °C ± 2 °C
Relative humidity	≤ 60%
Electrical requirements	110 V AC, 20 A – 230 V AC , 10 A
AC power (normal operation)	typical 2 kW

The conditions of the environment are preferred to be as stable as possible.

DRAWINGS

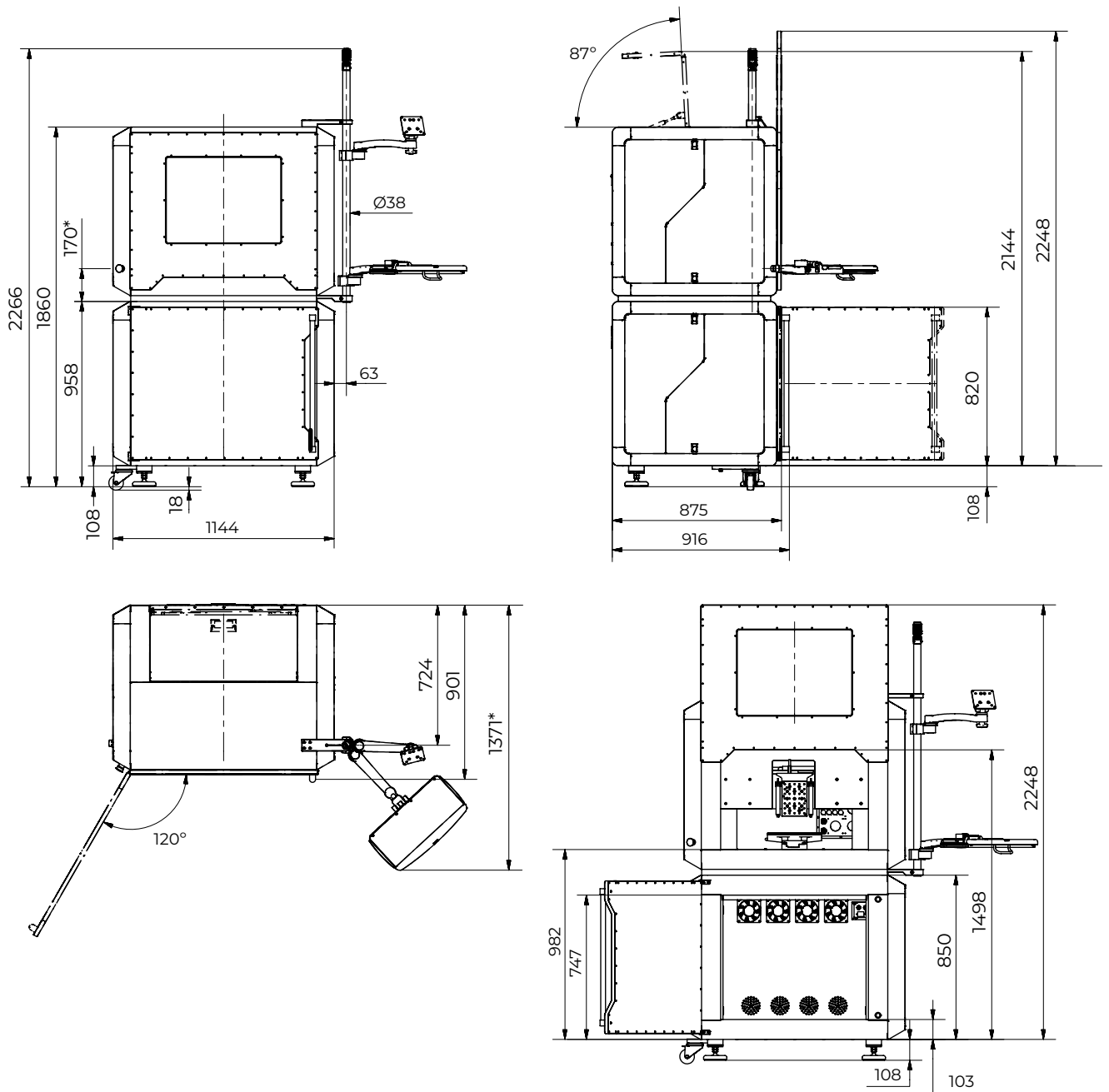

Figure 1. Laser Nanofactory dimensions in millimeters

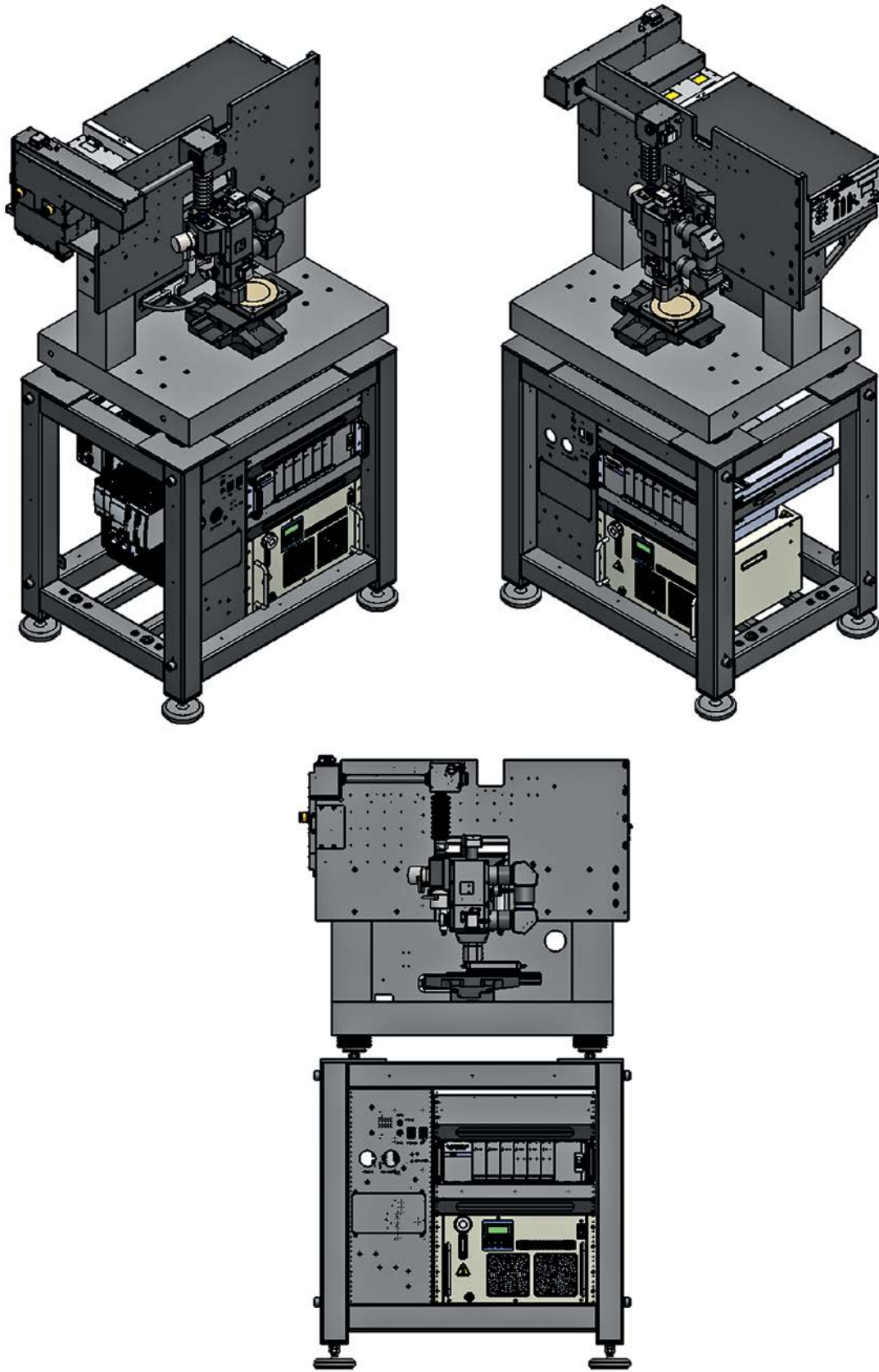

Figure 2. Laser Nanofactory drawings